

Carbon Steel Flanged Firesafe Ball Valve

Cast Steel Construction - ANSI 150

PRODUCT DATASHEET

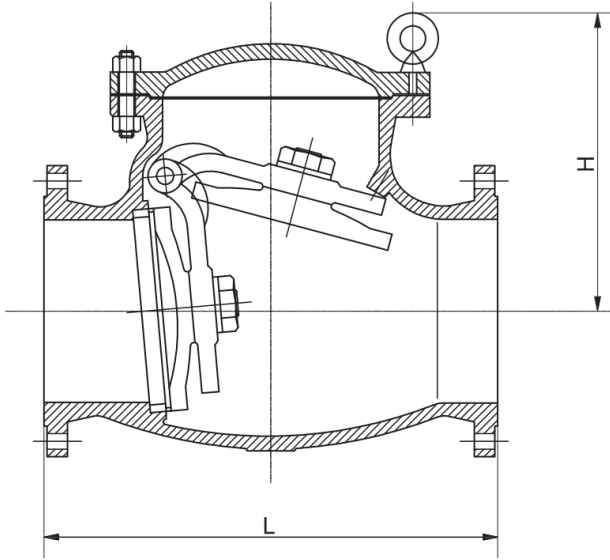

Features

- Size Range: 25mm (1") - 300mm (12")
- Steam Oil and Petro Chemical Industry
- Flanged ANSI 300 available on request
- For use with air, water, oil, gas & non-corrosive fluids, compatible with body & trim

Specifications

- ANSI B16.34 Design
- ANSI B16.5 Flange
- Max Working Temp: 300°C
- Cold Working Pressure: 1960kPa

Dimensions (mm)

Size	L	H	HOLE SIZE	HOLES	KG
25mm (1")	-	-	-	-	-
40mm (1 1/2")	203.2	135	20	4	19
50mm (2")	215.9	147	20	4	26
65mm (2 1/2")	241.3	178	20	4	31
80mm (3")	292.1	222	20	8	51
100mm (4")	355.6	314	22	8	85
200mm (8")	495.6	350	22	8	148
250mm (10")	622.3	406	26	12	218
300mm (12")	698.3	445	26	12	345

Materials

#	PART	MATERIAL
1	Body	WCB (ASTM A216)
2	Bonnet	WCB (ASTM A216)
3	Disc	410 (2Cr13)
4	Seat	H/F Stellite
5	Gasket	Graphite

Warranty

24 months

For Further Information

📧 info@valvewarehouseaustralia.com.au

☎ 03 9421 0042

Valve Warehouse ABN 33 632 515 149