

Mini-Rester

Hangsell 15mm – 20mm

Scope of Use / Specification Sheet

The Sioux Chief Mini-Rester is 'AA' size, ideal for use with dishwashers, and available in a chrome finish.

Product List

Order Code	Size	Model
7013	AA	15mm Conetite Tee
7012	AA	20mm Dishwasher – Chrome

Application

The Mini-Rester is ideal for installation on washing machine and dishwasher supply lines, single lever taps and all fast action tapware.

Materials

Body	Type L Copper
Piston	HHPP
O-Rings	EPDM
End Fittings	DR Brass
Thread	BSP

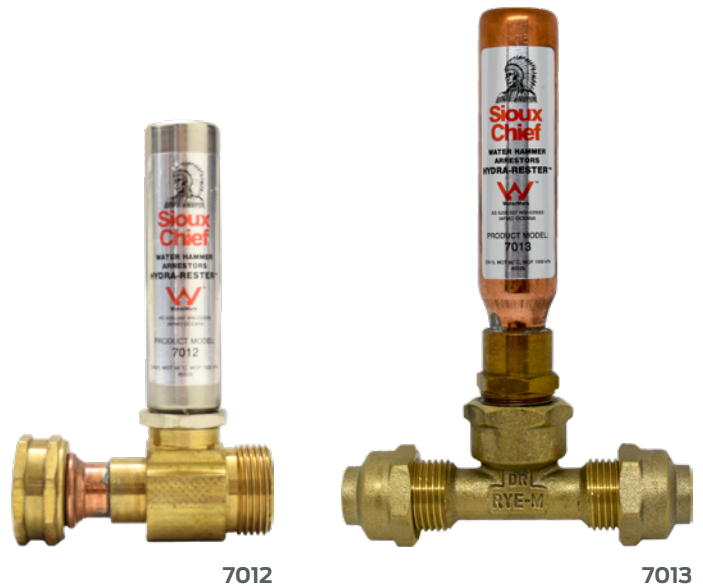

Features and Benefits

- Simple to install
- Maintenance free
- Cost effective
- Seamless shock absorbing chamber
- Suits hot and cold water
- Protects against fixture damage and flooding

Description

When a shuttering fixture closes, a pressure wave begins to move back along the pipe. As it reaches the arrestor the force acts against the arrestor piston, which, in turn, pushes against a charge of air. The air is then compressed, dissipating the wave energy and nullifying the hammering effects. Water Hammer Arrestors do not compensate for loosely fitted pipe work.

The Mini-Rester is formed from Type L copper tube and is cold rolled and spun closed seamless. The piston carries two EPDM seals and is lubricated with approved 111 Silicone Compound. System surge pressure can be kept below 1000kPa while the arrestor can operate at a safe working pressure to 2300kPa. The device is easily installed via the various BSP threaded fittings and can be mounted in any position 90° to the water flow.

Mini-Rester Hangsell 15mm – 20mm

Dimensions

Order Code	Length (A)	Diameter (B)	Tee (C)	Thread Size	Weight
7012	109	22.5	70	15	200g
7013	138.5	22.5	98	15	360g

Note: All measurements in mm unless otherwise stated.

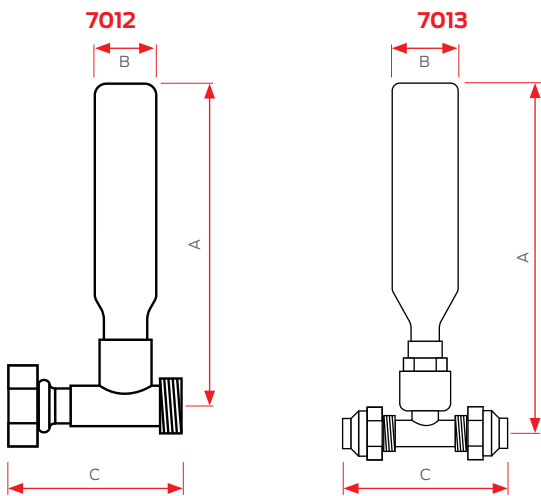

Scope of Use

Materials in contact with water	Copper, EPDM, PP, DR Brass
Maximum operating temperature	90°C
Maximum allowable operating pressure	1500kPa

Installation

Installation is subject to the requirements of the applicable regulatory authority, the National Construction Code Volume Three – Plumbing Code of Australia, associated reference standards as applicable at the time and AS/NZS 3500.1.

Standards and Approvals



AS 5200.007
WM-020003

Connection

The Mini-Rester can be easily installed at 90° to the water supply with the choice of fittings eliminating the need for special tools.

All plumbing systems must be structured in accordance with AS/NZS 3500.1 and utilise the correct clipping and supports.

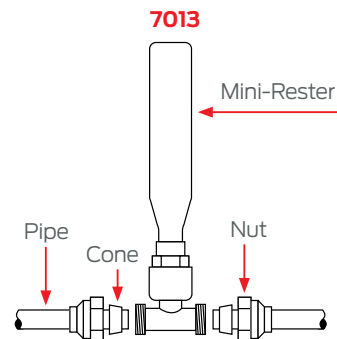
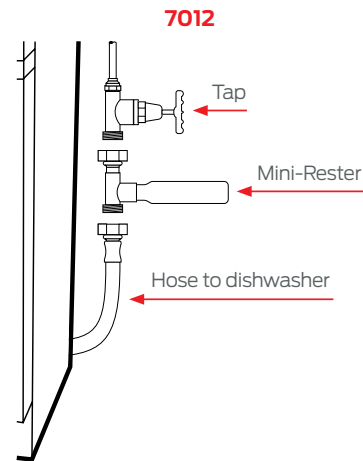

Warranty

Reliance Worldwide Corporation (Aust.) Pty. Ltd. (RWC) will either replace or repair any defective goods where the defect arose as a result of manufacture within the warranty period. You may contact RWC at the phone number, address or e-mail shown below for further information or to make a claim.

Visit www.rmc.com.au/warranty to view the warranty statement in full and for further important information.