

Gear Operated Butterfly Valve

Lugged - Ductile Iron - 316 Stainless Steel Disk -
EPDM Seat - WATERMARK

PRODUCT DATASHEET

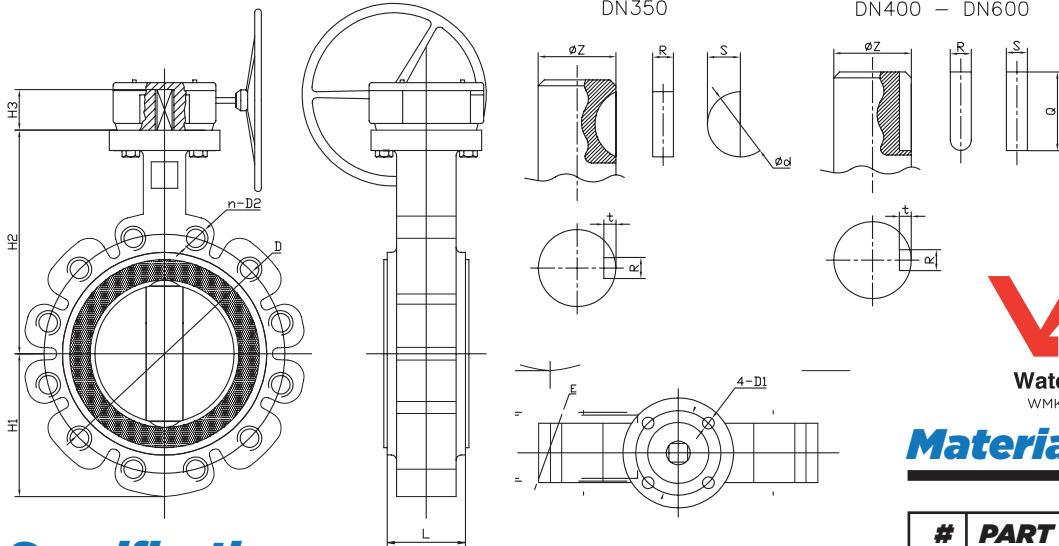

Materials

#	PART	MATERIAL
1	Body	Ductile Iron
2	Lower Bushing	Bronze
3	Stem	Stainless Steel 420
4	Seat	EPDM
5	Disc	316 Stainless Steel
6	Long Bushings	PTFE
7	Rivet	L3
8	Tag	Stainless Steel 304
9	Short Bushings	Bronze
10	O-ring	NBR
11	Split Ring	Gr 33
12	Circlip	Gr 33
13	Handle	Cast Iron

Specifications

- Max Cold Working Pressure: 1600 kPa (16 Bar)
- Flange drilling is Table E except for the 100mm (4") size, which is drilled Table D & E
- Top Flange: ISO 5211

Features

- Suitable for water and wastewater treatment and general industry.
- The thin compact butterfly valve body allows for easy installation in tight areas.
- When released the lever locks into position via a notch plate.

Dimensions (mm)

Imperial Size	H1	H2	H3	D	L	E	R	S	T	Z	OD	Q	4-D1	N-D2	KG/PC
14"	368	267	45	470	78	102	8	11	8	31.6	28	12	12	12-28.4	45
16"	400	298.6	51.2	521	102	140	10	10	5	33.15	45	18	18	16-28.4	78
18"	422	318	51.2	584	114	140	8	5	8	38	45	18	18	16-31.8	93
20"	480	355	64.2	641	127	140	10	10	8	41.15	56	18	18	20-31.8	130
24"	562	444	70.2	756	154	165	16	10	6	50.65	58	22	22	20-35.1	260

Warranty

24 months

For Further Information

📧 info@valvewarehouseaustralia.com.au

☎ 03 9421 0042

Valve Warehouse ABN 33 632 515 149