

316 Stainless Steel Swing Check Valve

Unidirectional Flow - F & F

PRODUCT DATASHEET

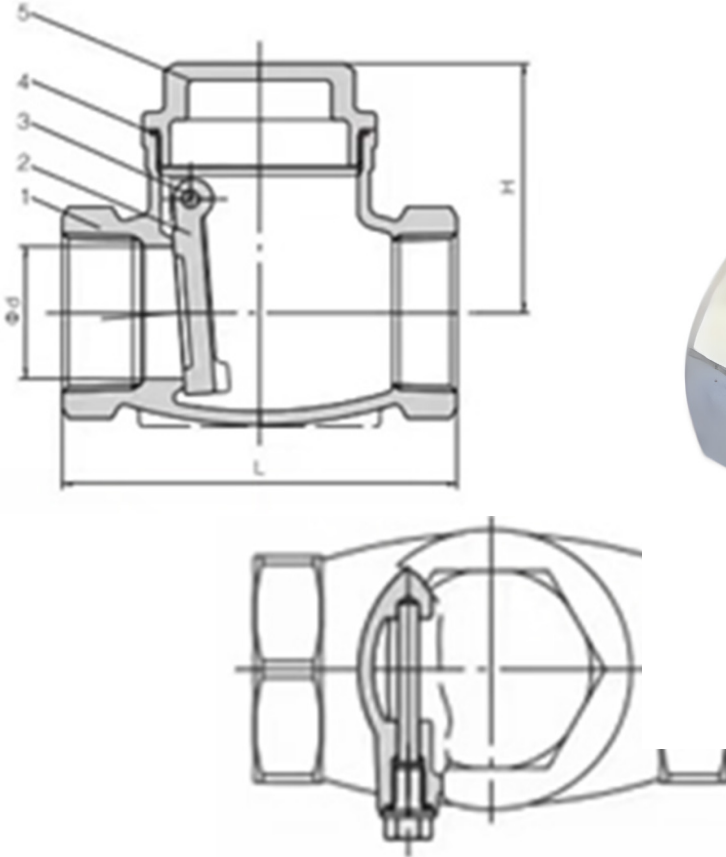

Features

- Suitable for water, oil, gas, chemicals, corrosive environments and liquids
- Designed to be installed in the horizontal position with the arrow on the valve matching the flow direction
- Prevents back flow by way of a hinged flap

Specifications

- Max Cold Working Pressure: 1400 kPa (14 BAR)
- Maximum Working Temperature: 200°C
- Thread: BSP to AS1722.1

Dimensions (mm)

Size	B	L	H
15mm (1/2")	25	62	41
20mm (3/4")	31	71.5	46
25mm (1")	37.5	84	50
32mm (1 1/4")	46	98	58
40mm (1 1/2")	52	111	63
50mm (2")	64	128	70

Materials

#	PART	MATERIAL
1	Body	Stainless Steel CF8M
2	Disc	Stainless Steel CF8M
3	Pin	Stainless Steel 316
4	Sealing Ring	PTFE
5	Bonnet	Stainless Steel CF8M

Warranty

24 months

For Further Information

📧 info@valvewarehouseaustralia.com.au

☎ 03 9421 0042

Valve Warehouse ABN 33 632 515 149