

316 Stainless Steel Ball Valve - 1 Piece

Reduced Bore - F & F

PRODUCT DATASHEET

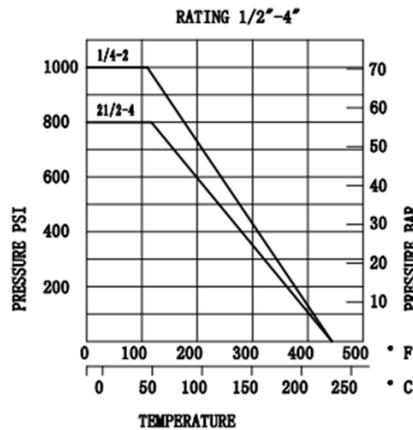
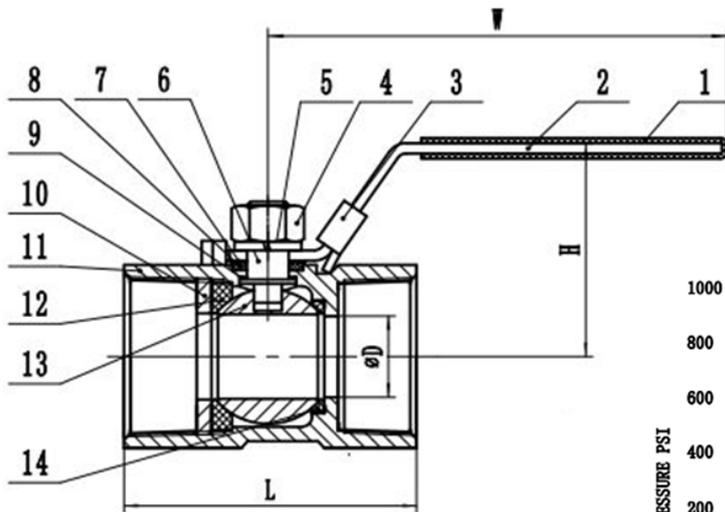

Features

- Suitable for isolating hot & cold non-potable water, oil and gas.
- Commonly used in the food processing and chemical service industries.
- Comes with a blow-out proof stem design and adjustable stem packing.
- Comes with a locking device on the lever.

Specifications

- Max Working Pressure: 1000 psi (6895 kPa)
- Max Working Temperature: 180°C
- Thread: BSP to ISO 228-1
- Reduced Bore

Dimensions (mm)

Size	D	L	H	W	S
8mm (1/4")	5	39.5	31	67	17
10mm (3/8")	6.8	43.5	34	87	20.5
15mm (1/2")	9.2	57	39	96	25
20mm (3/4")	12.5	59	44	96	31.5
25mm (1")	15	71	48	112	37.5
32mm (1 1/4")	20	78	54	112	47
40mm (1 1/2")	25	82.5	60	142	52
50mm (2")	32	99	66	142	64

Materials

#	PART	MATERIAL
1	Plastic Cover	Plastic
2	Handle	304 Stainless
3	Locking Nut	304 Stainless
4	Stem Nut	304 Stainless
5	Spring Washer	304 Stainless
6	Stem	316 Stainless
7	Pack Ring	304 Stainless
8	Stem Packing	PTFE

Warranty

24 months

For Further Information

info@valvewarehouseaustralia.com.au

03 9421 0042

Valve Warehouse ABN 33 632 515 149