

316 Stainless Steel Ball Valve - 2 Piece

Heavy Duty - Full Flow - F & F

PRODUCT DATASHEET

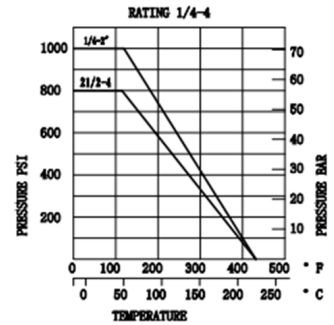
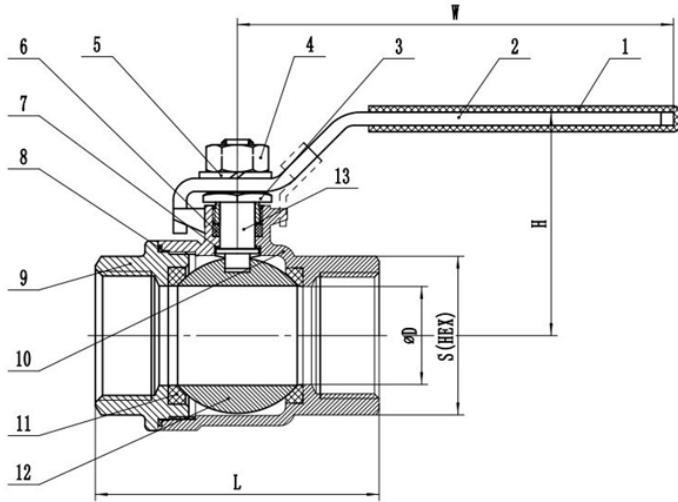

Features

- Suitable for isolating hot & cold non-potable water, oil and gas
- Commonly used in the food processing and chemical service industries
- Comes with a blow-out proof stem design and adjustable stem packing
- Comes with a locking device on the lever

Specifications

- Max Working Pressure: 1000 psi (6895 kPa)
- Max Working Temperature: 180°C
- Thread: BSP to ISO 228-1

Dimensions (mm)

Size	D	L	H	W	S
8mm (1/4")	11.6	48.5	44	94	19
10mm (3/8")	12.5	48.5	44	94	21
15mm (1/2")	15	58	50	104	25.5
20mm (3/4")	20	65	59	113	31
25mm (1")	25	77	65	128	37.5
32mm (1 1/4")	32	90	79	156	46
40mm (1 1/2")	38	98.6	83	156	52.5
50mm (2")	50	121	99	194	66
65mm (2 1/2")	64	145	128	246	82.5
80mm (3")	76	166	133	246	97.5
100mm (4")	94	240	175	317	130

Materials

#	PART	MATERIAL
1	Plastic Sleeve	Plastic
2	Handle	304 Stainless Steel
3	Gland Nut	304 Stainless Steel
4	Stem Nut	304 Stainless Steel
5	Spring Washer	304 Stainless Steel
6	Stem Packing	PTFE
7	Thrust Washer	PTFE
8	Joint Gasket	PTFE
9	Cap	CF8M Stainless Steel
10	Body	CF8M Stainless Steel
11	Ball Seat	PTFE
12	Ball	CF8M Stainless Steel
13	Stem	316 Stainless Steel

Warranty

24 months

For Further Information

📧 info@valvewarehouseaustralia.com.au

☎ 03 9421 0042

Valve Warehouse ABN 33 632 515 149